

Heart of your
Building

ISO Approved 9001-2008

18001215509

Toll Free

www.jeengineering.org



ISO APPROVED GERMAN
TECHNOLOGY HOME ELEVATOR

Type - HYDRAULIC, GEAR AND PINION, TRACTION
NOT REQUIRED PIT WELL, SHAFT, COUNTER WEIGHT

INTRODUCTION

JE Engineering is one of the fastest growing, Lift Manufacturing Company in India. We are highly advanced in Global Technology of Micro Controller, Control Panel with Serial Communication System. Our factory in South India, is equipped with unmatched manufacturing and technological infrastructure, including testing & arrangement with computer controlled machines, which ensure the reliability of the equipment installed by us.

We hope that our offer will be in line with your requirements and, wait for your valuable calls.

Thanking and assuring you the best of our services.

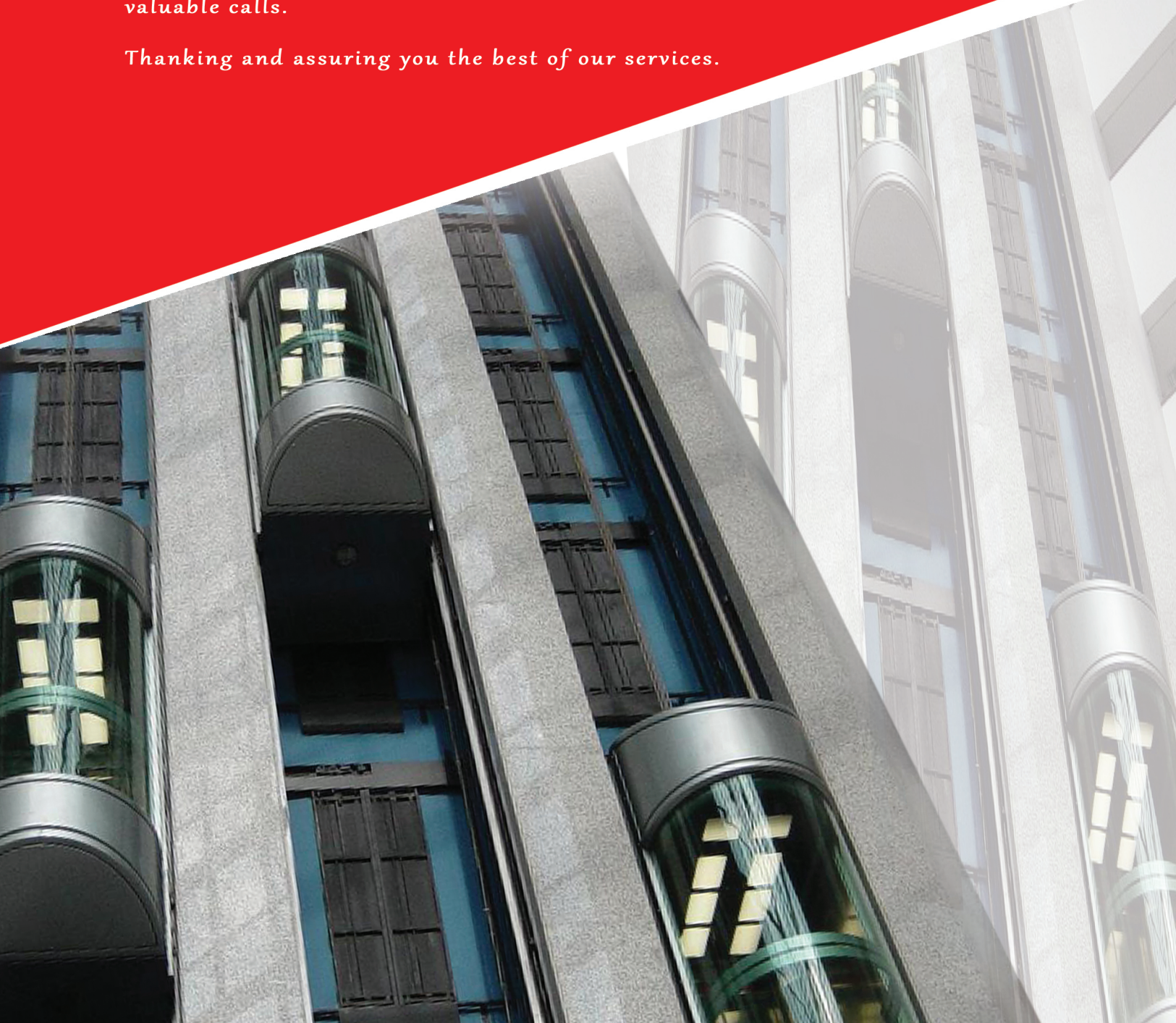

Product INTRODUCTION

Traction System

Geared traction machines are driven by AC or DC electric motors. Geared machines use worm gears to control mechanical movement of elevator cars by “rolling” steel hoist ropes over a drive sheave which is attached to a gearbox by a high speed motor.

Control System

The controller is contained within a cylindrical container about the size and shape of a cake container and this was operated via a projecting handle. This allowed some control over the energy supplied to the motor and so enabled the elevator to be accurately positioned.

Safety System

All elevators in the modern era have been fitted with several safety devices which prevent the elevator from simply free-falling and crashing. An elevator cab is typically borne by six or eight hoist cables, each of which is capable on its own of supporting the full load of the elevator plus twenty-five percent more weight.

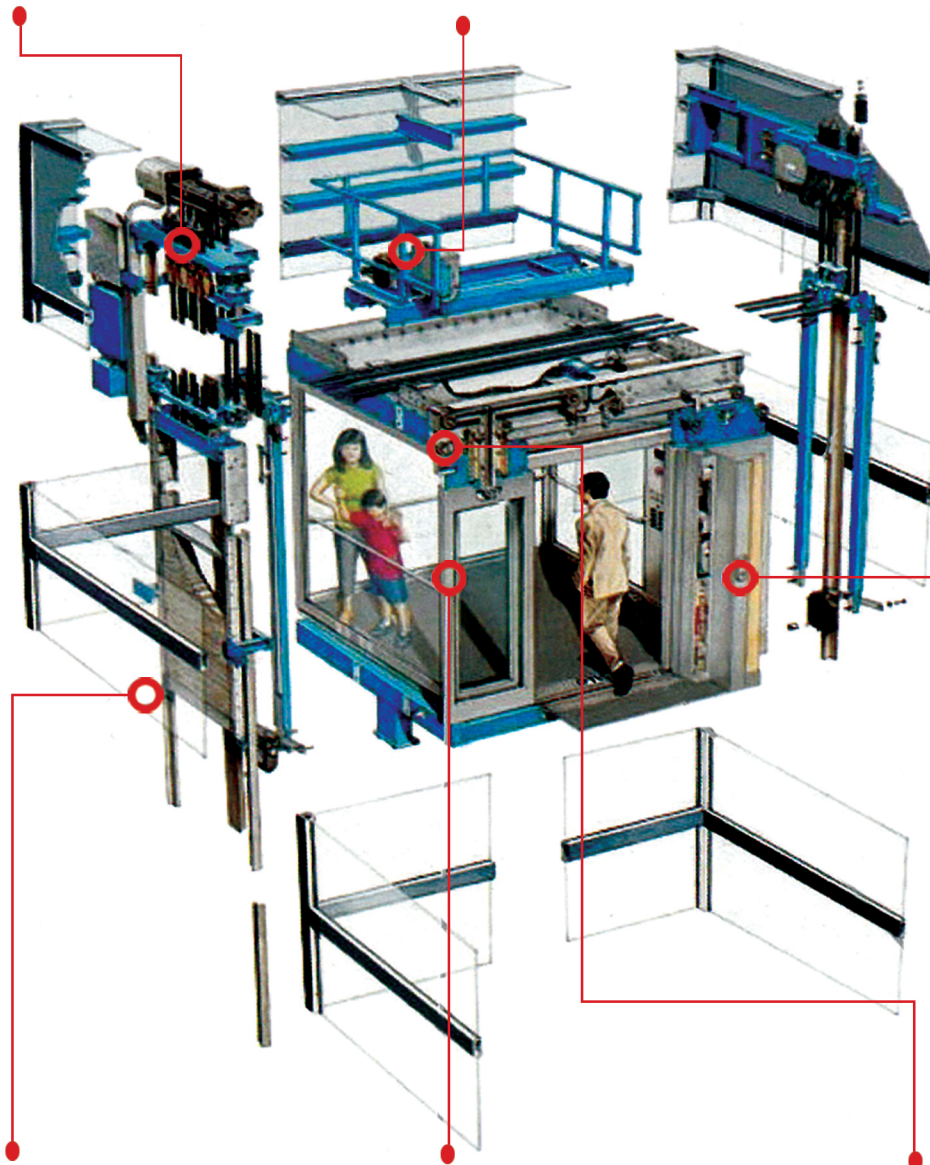

Guide System

Guide rails are part of the inner working of most elevator and lift shafts, functioning as the vertical, internal track.

Cabin System

Generally passenger elevators are available in capacities from 1,000 to 6,000 pounds (450-2,700 kg) in 500 pounds (230 kg) increments. Generally passenger elevators in buildings eight floors or less are hydraulic or electric, which can reach speeds up to 200 feet per minute (1.0 m/s) hydraulic and up to 500 feet per minute electric.

Door System

Elevator doors protect riders from falling into the shaft. The most common configuration is to have two panels that meet in the middle, and slide open laterally. In a cascading telescopic configuration, the doors run on independent tracks so that while open, they are tucked behind one another, and while closed, they form cascading layers on one side.

Machine Room (MR) Passenger Elevator

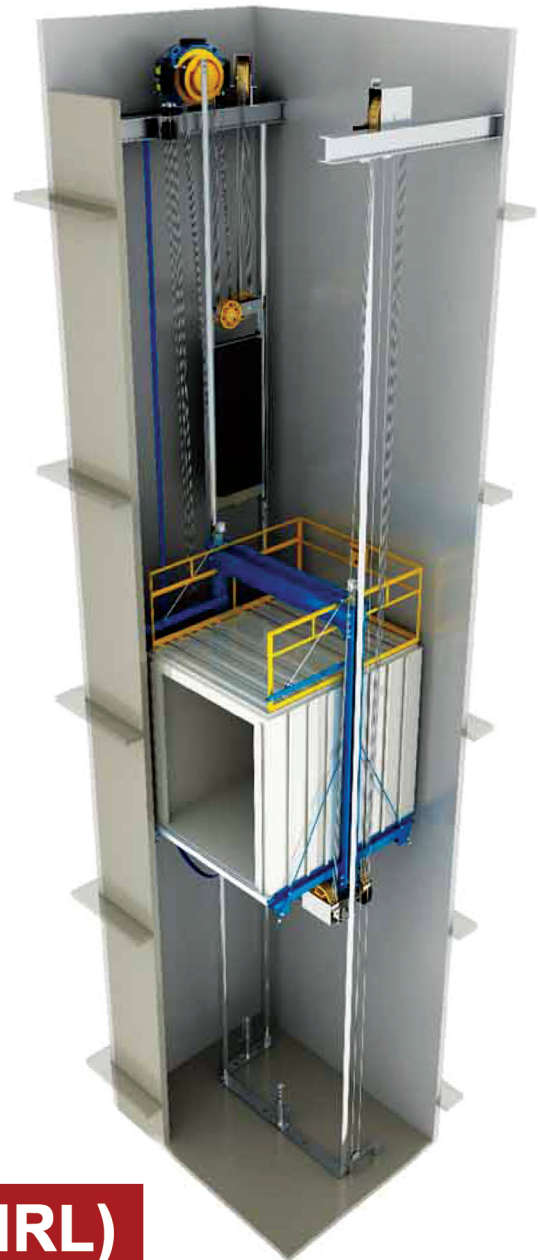

Machine Roomless (MRL) Passenger Elevator

CABIN SYSTEM

Elevator Cabin

Commerical Cabin Series



JE -CB-101

Ceiling Decoration
 Double Vaulted White Transparent Plate with Middle Diamond Transparent Light for Soft Illumination Design

Car Side and Car back
 Center Board : Etching Finish; Mirror Finish; Hairline Finish
 Auxiliary Board : Hairline Finish

Handrail : Organic Board Handrail
Car Floor Decoration : PVC Floor (2mm thickness)



JE -CB-102

Ceiling Decoration
 Based on Chinese wooden modeling with white transparent board.

Car Side and Car back
 Center Board : Etching Finish; Mirror Finish; Hairline Finish
 Golden Color for Concave
 Auxiliary Board : Hairline Finish

Handrail : Stainless Steel Hairline Tube
Car Floor Decoration : PVC Floor (2mm thickness)

Load (kg)	Speed (m/s)	Cabin Inner Size(mm)		Cabin Outsize(mm)		Door Opening Width JJ (min)	Door Opening Method
		Width	Depth	Width	Depth		
450	1.0-1.75	1400	850	1460	1020	800	CO
630	1.0-1.75	1400	1100	1460	1270	800	CO
800	1.0-1.75	1400	1350	1460	1520	800	CO
900	1.0-2.5	1600	1350	1700	1520	900	CO
1000	1.0-3.0	1600	1500	1700	1670	900	CO
1250	1.0-3.0	1950	1400	2050	1570	1100	CO
1600	1.0-3.0	1950	1750	2050	1920	1100	CO



JE -CB-103

Ceiling Decoration
 Middle with Vaulted image Roof, Side of Stainless Steel Floor with Tube Lamp for Soft Illumination Design.

Car Side and Car back
 Center Board : Etching Finish; Mirror Finish; Hairline Finish
 Auxiliary Board : Hairline Finish

Handrail : Stainless Steel Hairline
Car Floor Decoration : PVC Floor (2mm thickness)

JE -CB-104

Ceiling Decoration
 Wide Vaulted White Transparent Light Board for Soft Illumination Design

Car Side and Car back
 Center Board : Etching Finish; Mirror Finish; Auxiliary Board : Hairline Finish

Handrail : Stainless Steel Hairline Tube (single)
Car Floor Decoration : PVC Floor (2mm thickness)



JE -CB-105

Ceiling Decoration
 Wide Vaulted White image for soft Illumination Design

Car Side and Car back
 Center Board : Etching Finish; Mirror Finish; Hairline Finish
 Auxiliary Board : Hairline Finish

Handrail : Stainless Steel Hairline Tube (single)
Car Floor Decoration : PVC Floor (2mm thickness)



JE -CB-106

Ceiling Decoration
 Wide Vaulted White Transparent Light Board for Soft Illumination Design

Car Side and Car back
 Center Board : Etching Finish; Mirror Finish; Hairline Finish ; Titanium Finish; Striated Finish
 Auxiliary Board : Etching Finish; Hairline Finish ; Titanium Finish; Striated Finish

Handrail : Round Wood and Titanium
Car Floor Decoration : PVC Floor (2mm thickness)



JE -CB-107

Powder Coated Steel Cabain
 Car ceiling : Painted steel
 Car wall : Painted steel
 Floor : PVC
 Car door : Painted steel

CABIN SYSTEM

Door Panel

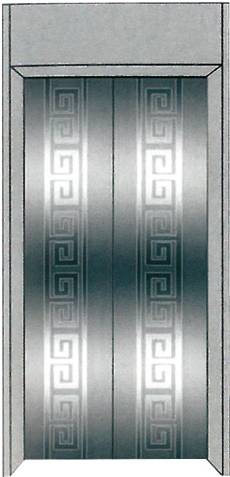

JE -PN-201
Mirror, Hairline Etching



JE -PN-202
Mirror, Etching, Hairline



JE -PN-203
Mirror, Etching



JE -PN-204
Mirror, Etching, Hairline

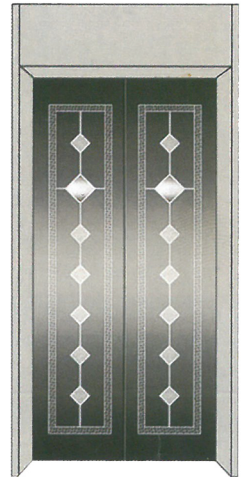

JE -PN-205
Mirror, Etching, Hairline



JE -PN-206
Big vision glass door



JE -PN-207
Powder coated steel door



JE -PN-208
Mirror, etched (optional titanium gold mirror, etched)



JE -PN-209
Titanium gold, mirror, etched stainless steel, irregular grain (optional stainless steel mirror, etched)



JE -PN-210
Mirror, etched, stainless steel, golden recess

Elevator Floor



JE -FL-401



JE -FL-402



JE -FL-403



JE -FL-404

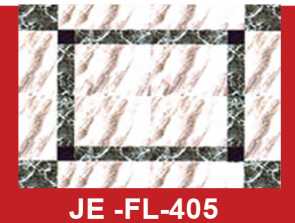

JE -FL-405



JE -FL-406



JE -FL-407



JE -FL-408

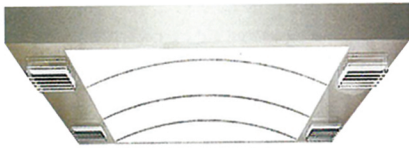

JE -CL-301
Mirror st./st. frame with acrylic top pannel, down light.

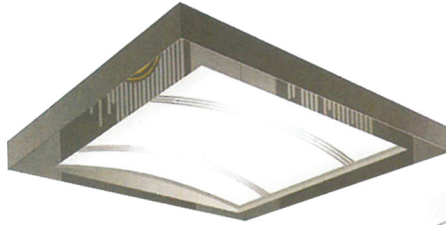

JE -CL-302
Mirror st./st. frame with acrylic top panel.

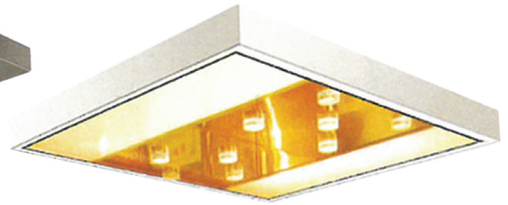

JE -CL-303
Golden mirror st./st. frame with acrylic top panel, down light.

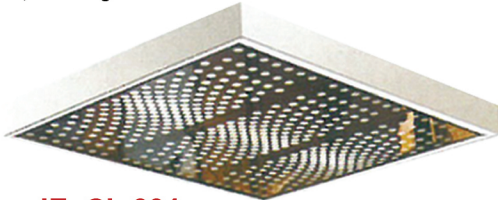

JE -CL-304
Mirror st./st. frame with acrylic top panel, down light.



JE -CL-305
Mirror st./st. frame with acrylic top panel, down light.



JE -CL-306
Simple stainless steel roof with soft LED lighting



JE -CL-307
Diamond silver painted steel with acrylic photic board



JE -CL-308
Mirror stainless steel framework acrylic arched top plate, intermediate down lamp decoration

False Ceiling Lazer Cut Models

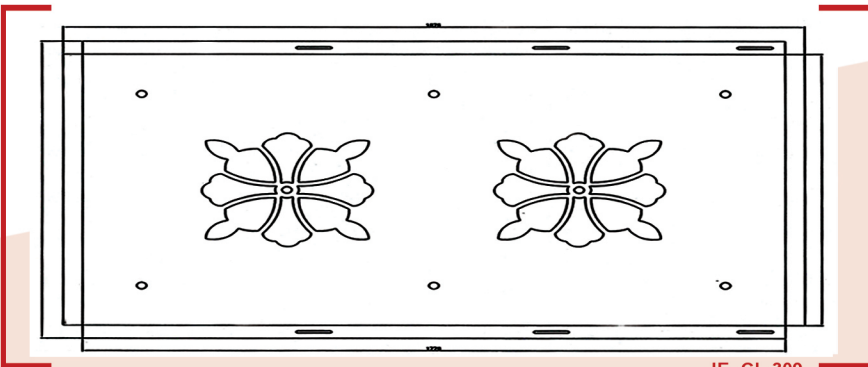

JE -CL-309

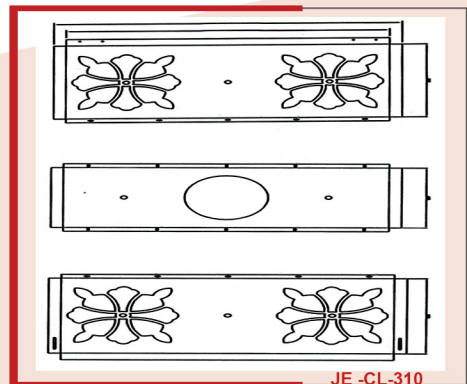

JE -CL-310

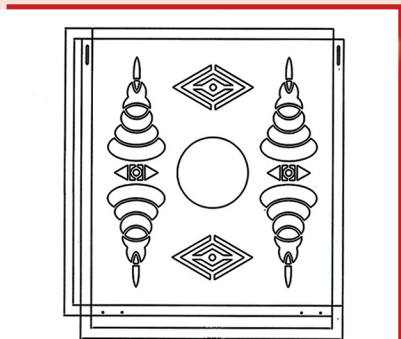

JE -CL-311

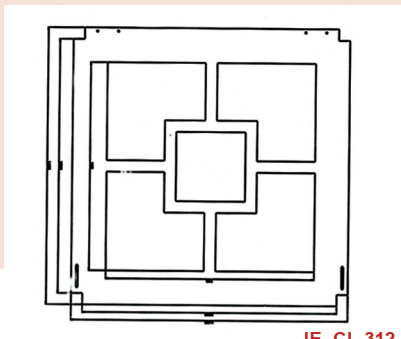

JE -CL-312

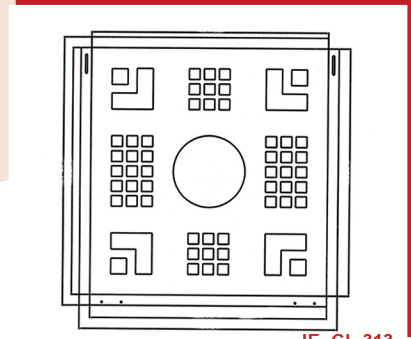

JE -CL-313

Controller

Home Lift



Gearless



Geared

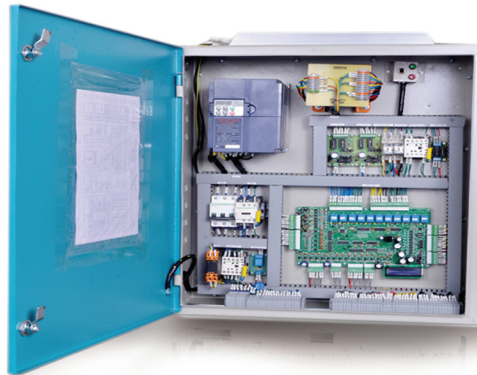

Motor

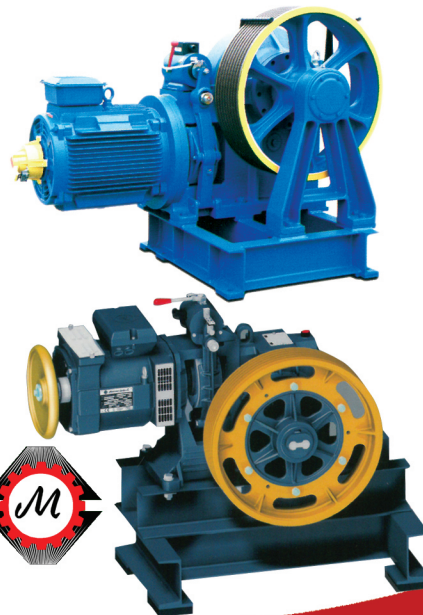

LOP & COP

Export Quality



Home Elevator

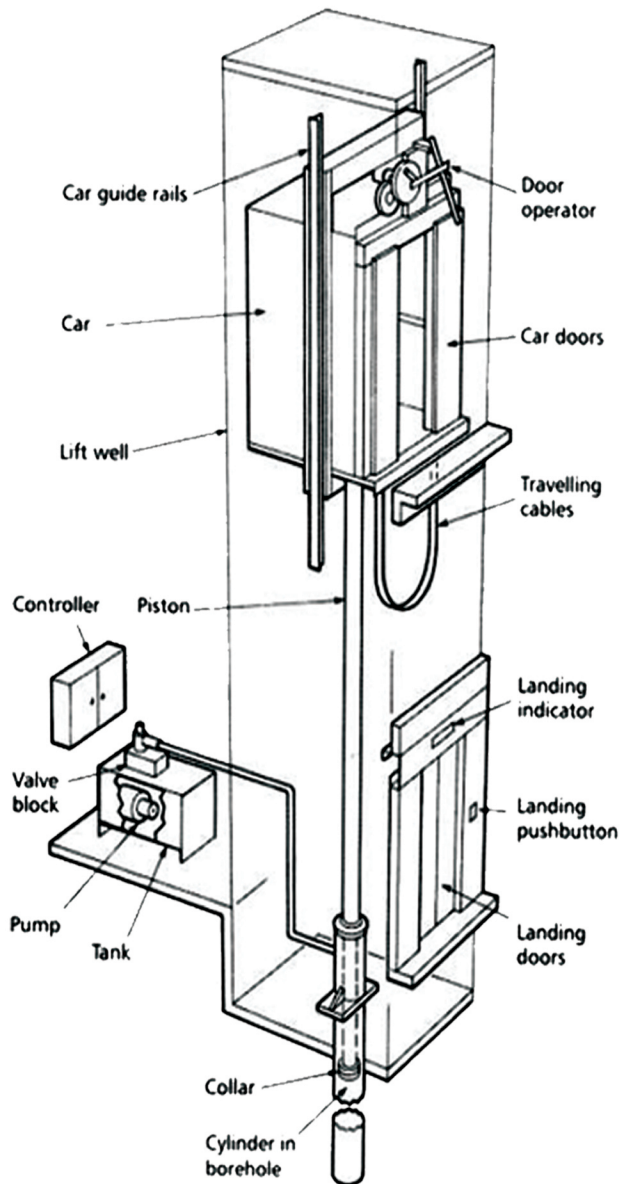
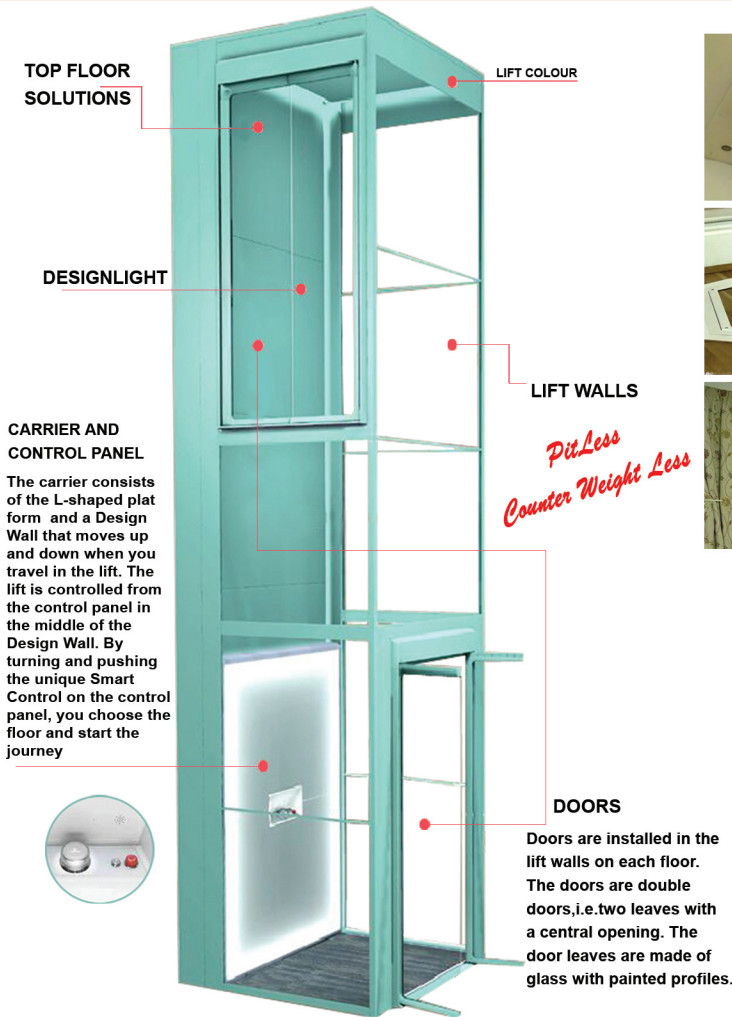

Hydraulic Home Lift

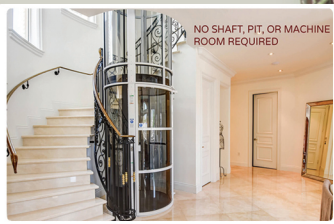

Traction Home Lift



Passenger Elevator Series Construction Parameters

Passenger elevator (Geared Machine)

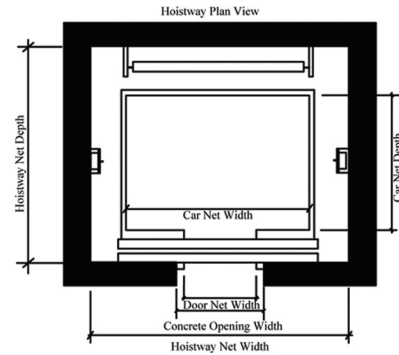
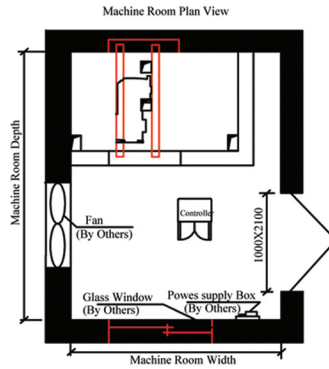
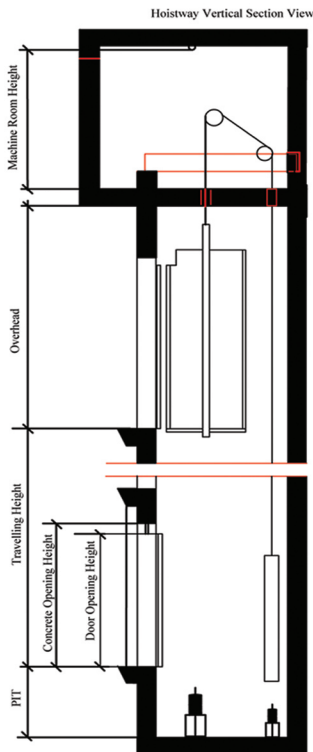

Capacity kg	No of Persons	Speed (m/s)	Entrnce (WxH)mm center opening	Car net size (W x D)mm	Shaft (w x D)	Dimension		Machine room size (W x D X H)mm
						PP	OH	
450	6	10	700 x 2100	1150 x 1100	1700 x 1800	1400	4200	2200 x 3600 x 2500
		1.5/1.75				1600	4400	
830	8	10	800 x 2100	1300 x 1250	1850 x 1900	1400	4200	2400 x 3600 x 2500
		1.5/1.75				1600	4400	
800	10	10	800 x 2100	1500 x 1300	2050 x 1950	1400	4200	2600 x 3800 x 2500
		1.5/1.75				1600	4400	
1000	13	10	900 x 2100	1600 x 1500	2150 x 2150	1400	4200	2800 x 4000 x 2500
		1.5/1.75				1600	4400	
1250	16	10	1000 x 2100	1750 x 1600	2300 x 2250	1400	4200	3000 x 4200 x 2500
		1.5/1.75				1600	4400	
1600	21	10	1100 x 2100	2050 x 1700	2600 x 2450	1400	4200	3300 x 4500 x 2500
		1.5/1.75				1600	4400	

Compact machine room passenger elevator (Gearless Machine)

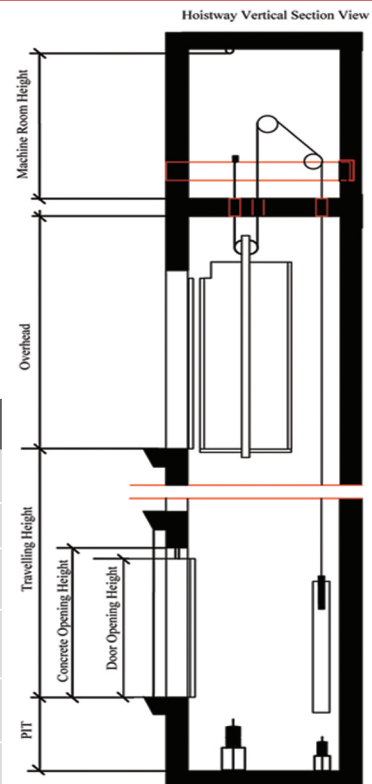
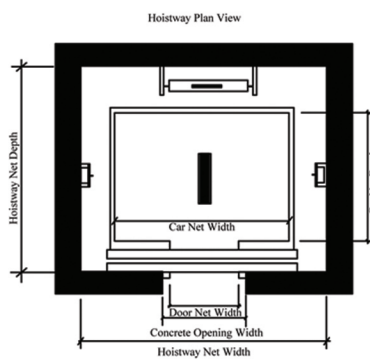
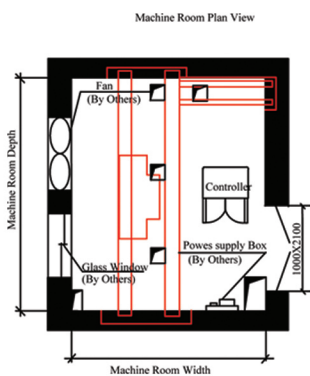

Capacity kg	No of Persons	Speed (m/s)	Entrnce (WxH)mm center opening	Car net size (W x D)mm	Shaft (w x D)	Dimension		Machine room size (W x D X H)mm
						PP	OH	
450	6	10	700 x 2100	1150 x 1100	1700 x 1800	1400	4200	1700 x 1800 x 2500
		1.5/1.75				1600	4400	
630	8	10	800 x 2100	1300 x 1250	1850 x 1900	1400	4200	1850 x 1950 x 2500
		1.5/1.75				1600	4400	
800	10	10	800 x 2100	1500 x 1300	2050 x 2000	1400	4200	2050 x 2000 x 2500
		1.5/1.75/2.0				1600	4600	
		2.5				1800	4800	
1000	13	10	900 x 2100	1600 x 1500	2150 x 2200	1400	4200	2150 x 2200 x 2500
		1.5/1.75/2.0				1600	4600	
		2.5				1800	4800	
1250	16	10	1000 x 2100	1750 x 1600	2700 x 2050	1400	4200	2700 x 2050 x 2500
		1.5/1.75/2.0				1600	4600	
		2.5				1800	4800	
1600	21	10	1100 x 2100	2050 x 1700	3000 x 2150	1400	4200	3000 x 2150 x 2500
		1.5/1.75/2.0				1600	4600	
		2.5				1800	4800	

Villa elevator

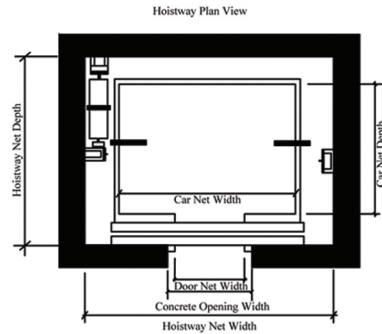
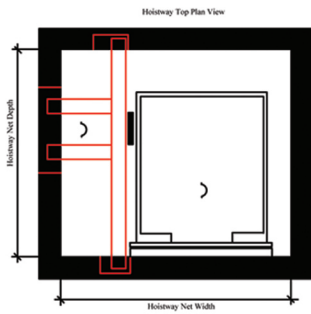
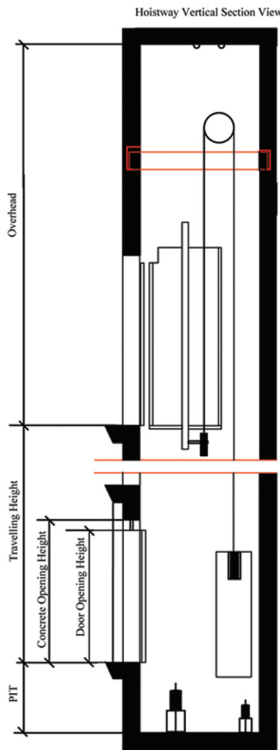

Capacity kg	No of Persons	Speed (m/s)	Entrnce (WxH)mm center opening	Car net size (W x D)mm	Shaft (w x D)	Dimension	
						PP	OH
450	6	10	700 x 2100	1100 x 1150	2000 x 1700	1500	4200
		1.5/1.75				1700	4400
830	8	10	800 x 2100	1300 x 1250	2200 x 1800	1500	4200
		1.5/1.75				1700	4400
800	10	10	800 x 2100	1450 x 1350	2350 x 1850	1500	4200
		1.5/1.75				1700	4400
1000	13	10	900 x 2100	1600 x 1500	2500 x 1950	1500	4200
		1.5/1.75				1700	4400
1250	16	10	1000 x 2100	1750 x 1600	2800 x 2050	1600	4200
		1.5/1.75				1800	4400
1600	21	10	1100 x 2100	2050 x 1700	3100 x 2150	1600	4200
		1.5/1.75				1800	4400

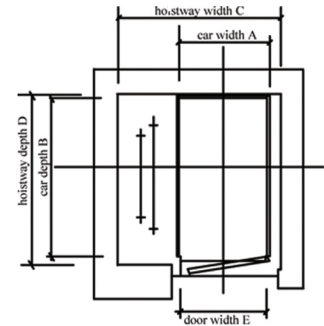
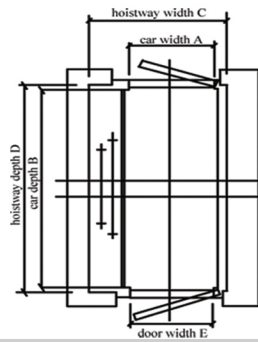
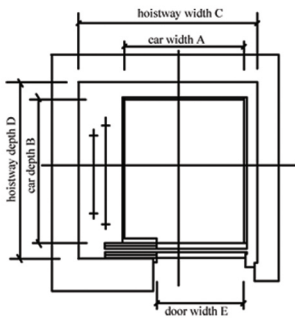

Side Opening Door							
Rated Load	A (mm)	B (mm)	C (mm)	D (mm)	E (mm)	Pit (mm)	Overhead (mm)
250kg	900	1200	1450	1550	700	400	3200
320kg	900	1300	1450	1650	700	400	3200

Manually Operated Door (Double entrance)							
Rated Load	A (mm)	B (mm)	C (mm)	D (mm)	E (mm)	Pit (mm)	Overhead (mm)
250kg	900	1200	1500	1270	900	400	3200
320kg	900	1300	1500	1370	900	400	3200

Manually Operated Door							
Rated Load	A (mm)	B (mm)	C (mm)	D (mm)	E (mm)	Pit (mm)	Overhead (mm)
250kg	900	1200	1500	1350	900	400	3200
320kg	900	1300	1500	1450	900	400	3200

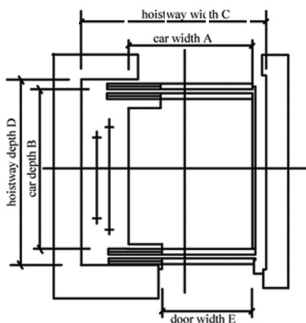

Side Opening Door (Double entrance)							
Rated Load	A (mm)	B (mm)	C (mm)	D (mm)	E (mm)	Pit (mm)	Overhead (mm)
250kg	900	1200	1450	1690	700	400	3200
320kg	900	1300	1450	1790	700	400	3200

Center Opening Door							
Rated Load	A (mm)	B (mm)	C (mm)	D (mm)	E (mm)	Pit (mm)	Overhead (mm)
250kg	1100	900	1400	1500	600	400	3200
320kg	1200	900	1450	1500	600	400	3200

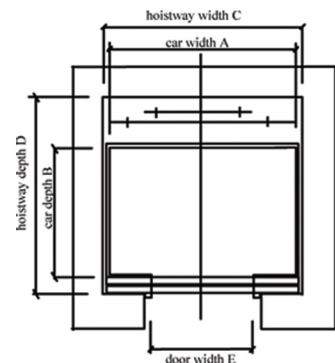

DOOR SYSTEM

Center Opening VVVF Door Operator

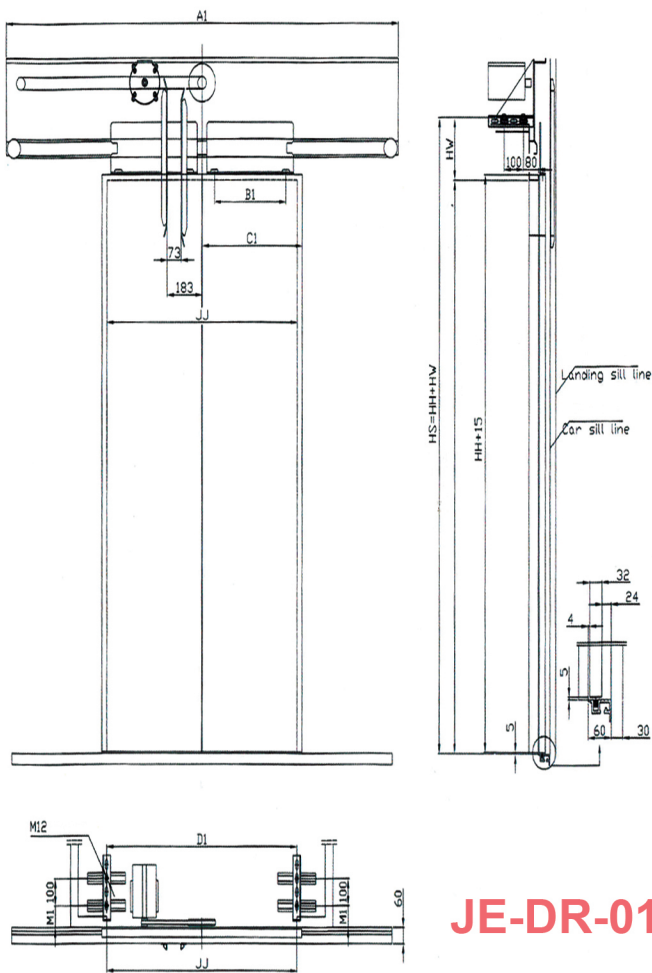
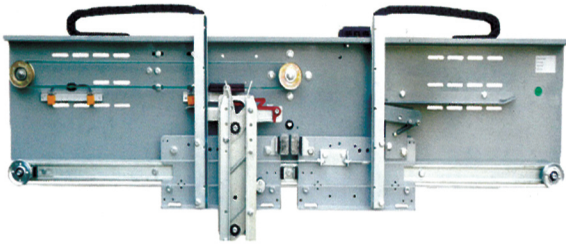

JE-DR-01

JJ	700	800	900	1000	1100	1200	1300	1400
A1	1460	1660	1860	2060	2260	2460	2660	2860
B1	225	275	325	375	425	575	525	575
C1	375	425	475	525	575	625	675	725
D1	1050	1050	1050	1050	1050	1200	1300	1400

Center Opening Landing Door Device

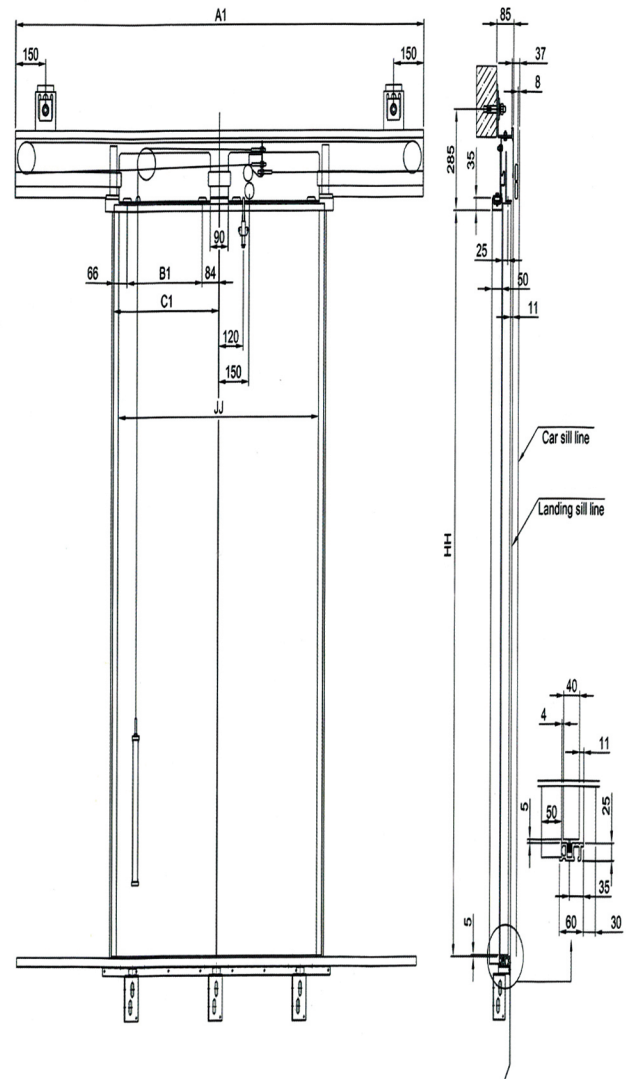
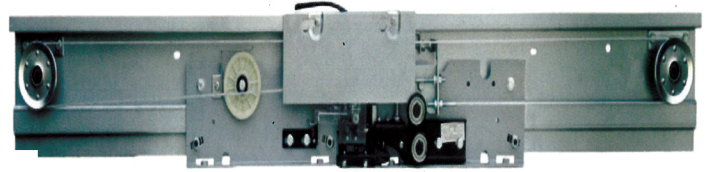

JE-DR-02

JJ	700	750	800	850	900	950	1000	1050	1100	1150	1200	1250	1300	1350	1400
A1	1140	1540	1640	1740	1840	1940	2040	2140	2240	2340	2440	2540	2640	2740	2840
B1	225	250	275	300	325	350	375	400	425	450	475	500	525	550	575
C1	375	400	425	450	475	500	525	550	575	600	625	650	675	700	725

DOOR SYSTEM

Center Opening Car Door

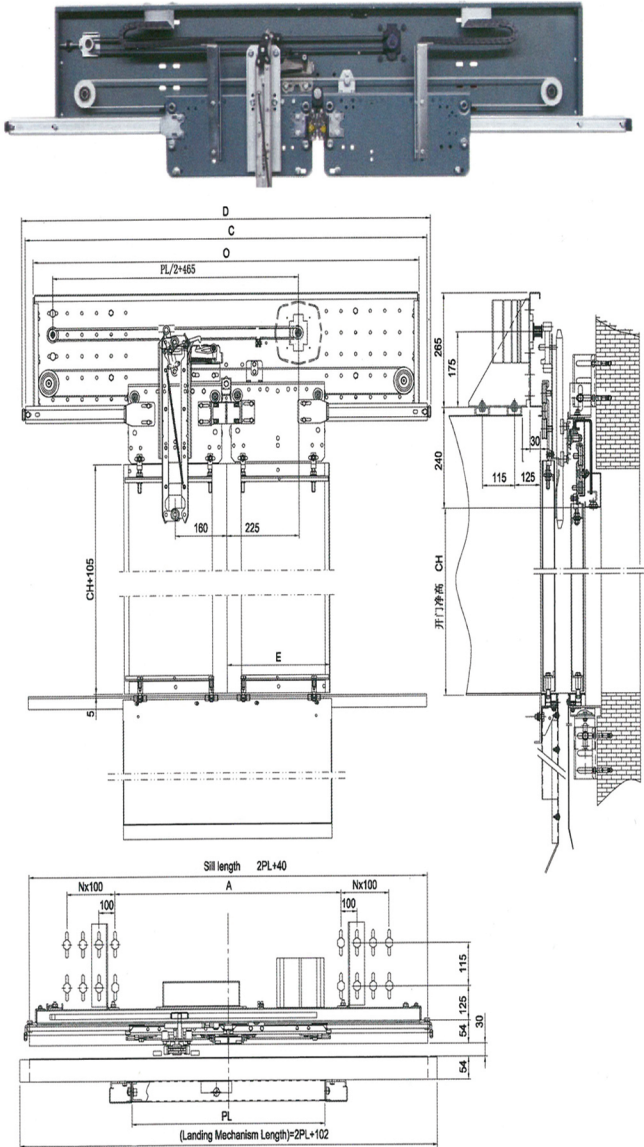

JE-DR-03

PL	600	650	700	750	800	850	900	1000	1100	1200
A	785	785	785	785	785	885	885	885	885	885
C	1250	1350	1450	1550	1650	1750	1850	2050	2250	2450
D	1270	1370	1470	1570	1670	1770	1870	2070	2270	2470
O	1200	1250	1400	1450	1500	1550	1600	1700	1800	2200
E	320	345	370	395	420	445	470	520	570	620
N	1	1	2	2	2	2	2	3	3	3
(s)	1.22	1.27	1.32	1.37	1.41	1.45	1.5	1.58	1.66	1.73
(kg)										
0.75%	52.5	57	61.5	66	70	74.5	79	87.5	96.5	105

Center Opening Landing Door Device

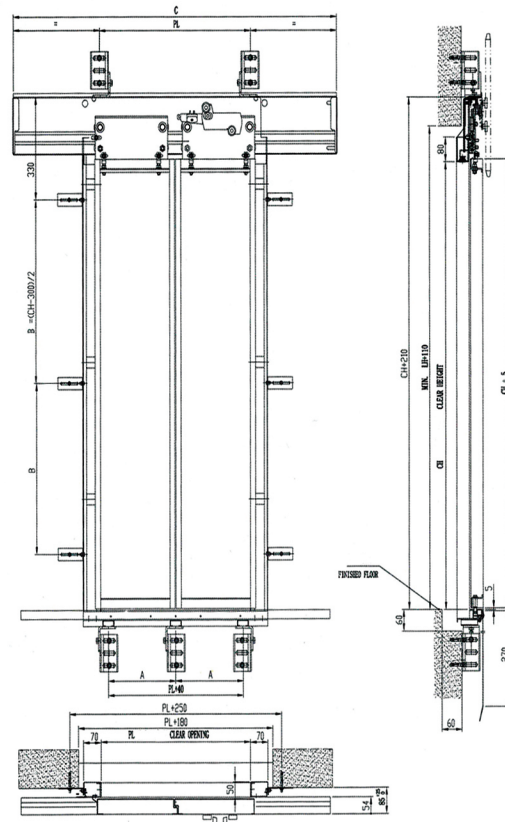
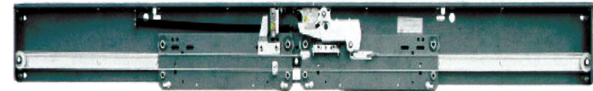

JE-DR-04

PL	700	800	900	1000
C	1500	1700	1900	2100
A	300	350	267	300
S	3	3	4	4
T	5	5	6	6

S: Number of Supports for Support Track

T: Total Number of Supports

◀ Elevator Handrail ▶



JE -HR-501 Surface: Stainless steel tube with matt short hairline
Specification (mm): $\phi 51$

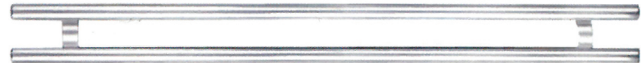

JE -HR-502 Surface: Mirror stainless steel tube
Specification (mm): $\phi 38$



JE -HR-503 Surface: Hairline plate with square head
Specification (mm): width 100



JE -HR-504 Surface: Stainless steel tube with short hairline and arc head
Specification (mm): width 80



JE -HR-506 Surface: Titanium stainless steel tube with short hairline and arc head
Specification (mm): width 80

ACCESSORIES

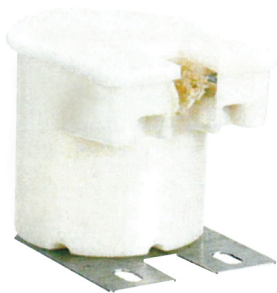

JE -ACE-601 Oil Can

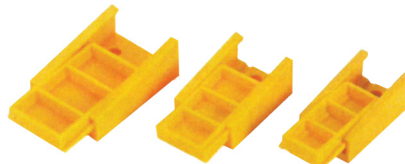

JE -ACE-602 Cable clamp



JE -ACE-603 Bull Dog Clip



JE -ACE-604 Fan

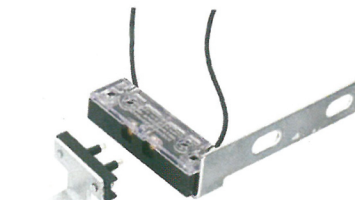

JE -ACE-605 Landing Door Switch



JE -ACE-607 S3 Limit Switch



JE -ACE-606 Rope Anchorage

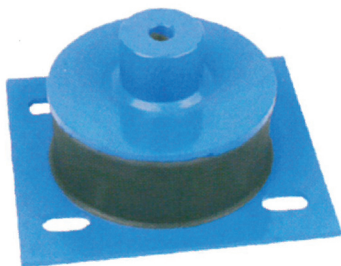

JE -ACE-608 Damping Pad

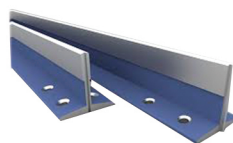

JE -ACE-609 Guide Rails



JE -ACE-610 Counterweight Block

ACCESSORIES ACCESSORIES

ACCESSORIES ACCESSORIES

ACCESSORIES



JE -ACE-611 Guide Shoe



JE -ACE-612 Brackets



JE -ACE-613 Rail Guide Clips

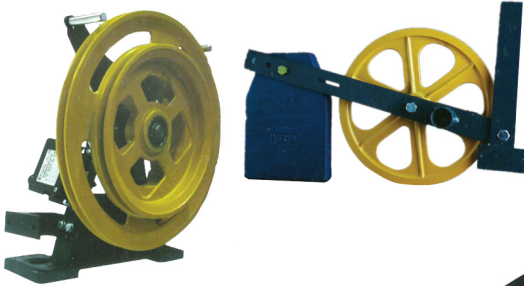

JE -ACE-614 Speed Governor

JE -ACE-615 Tension Pulley

JE -ACE-617 Safety Rope

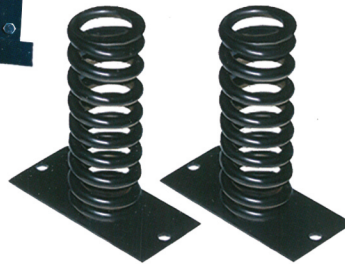

JE -ACE-616 Spring



JE -ACE-618
Trunking (MS&PVC)

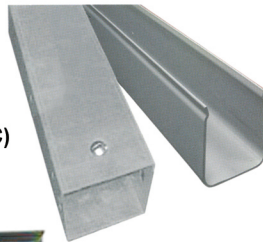

JE -ACE-620 Light Curtain

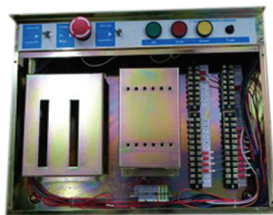

JE -ACE-621 Junction Box



JE -ACE-619 Magnets

JE -ACE-623 Travelling Cable(Flat)



JE -ACE-624 Stop switch

JE -ACE-622
Limit Switch



JE -ACE-626 Overload
Switch



JE -ACE-627 Pencil type
reed switch



JE -ACE-625 Inspection

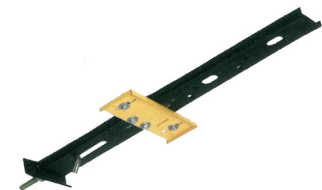

JE -ACE-628 Magnet Bkt.

EDATHINATTU BUILDING



JE ENGINEERING
LIFT MANUFACTURING
 GOVT. APPROVED TECHNICAL ACADEMY



Ph: 0481 2416555
 Mob / Whats App : 8592849995
 E-mail: Info@jeengineering.org
 Web: www.jeengineering.org

HEAD OFFICE

JE ENGINEERING

Lift Manufacturing
 Edathinattu Building, Manthurutty P.O, Karukachal
 Kerala, India Pin : 686542
 email: Info@jeengineering.org
 www.jeengineering.org

Fax 04812416255 Office 04812416555
 Contact: 08592849992, 08592849993, 08592849994, 08592849995,
 08592849996, 08592849997, 08592849998

OUR BRANCHES

Saudi Arabia

JE ELEVATORS
 Post 56044 , Malas
 Riyadh 11554, K S A
 Contact # 00966-592819990
 email: Info@jeengineering.org

JE ELEVATORS
 Post 0001 , ABHA
 ABHA 610984, K S A
 Contact # 00966-541544333
 email: Info@jeengineering.org

USA

JE HOME ELEVATORS SOLUTIONS
 Post 115, Tennessee Street
 Monroe, Air Port Road
 LOUISIANA 71203, U S A
 Contact # 001-318- 547 6401
 email: Info@jeengineering.org

Abudhabi

JE ELEVATORS
 Post 50182 , BLDG 66
 MUSSAFA, SHABIAH 10
 ABUDHABI , U A E
 Contact # 00971- 563776792
 email: Info@jeengineering.org

Bahrain

JE ELEVATORS
 Block 32, Bldg 1501, FI/306
 AL GUDAIBIYA
 MANAMA , BAHRAIN
 Contact # 00973-33432007
 email: Info@jeengineering.org

World cities



- Kerala
- Louisiana
- Dubai
- Bahrain
- Abha
- Riyadh